

2 PIECES BALL VALVES FLANGED ISO PN 16



ISO 9001:2008

BUREAU VERITAS
Certification



Size : DN 15 to 300 mm
Ends : ISO PN16/40 R.F. Flanges
Min Temperature : - 20°C
Max Temperature : + 200°C
Max Pressure : 40 Bars up to DN50 (16 bars over)
Specifications : ISO 5211 mounting pad
PTFE filled with glass seat
Anti blow-out stem
Atex
Fire safe according to API607 up to DN150

Materials : Carbon steel or Stainless steel

2 PIECES BALL VALVES FLANGED ISO PN 16

SPECIFICATIONS :

- Full bore
- Anti blow-out stem
- Double antistatic device
- PTFE filled with glass seat
- Locking device
- ISO 5211 mounting pad
- 2 pieces type (Split body)
- Hollowed ball from DN125 to DN300
- With exhaust hole in the ball (located in the top of the ball to avoid overpressure in it)
- Primer coating for carbon steel valves (Ref. 762)

USE :

- Chemical industries, petrochemical industries, hydraulic installation, compressed air, heating and water distribution
- Steam : 11 bars maximum
- Min and max Temperatures Ts : -20°C to + 200°C
- Max Pressure Ps : 40 bars up to DN50, 16 bars over (see graph under)

PRESSURE / TEMPERATURE GRAPH (STEAM EXCLUDED) :

PRESSURE

(Bar)

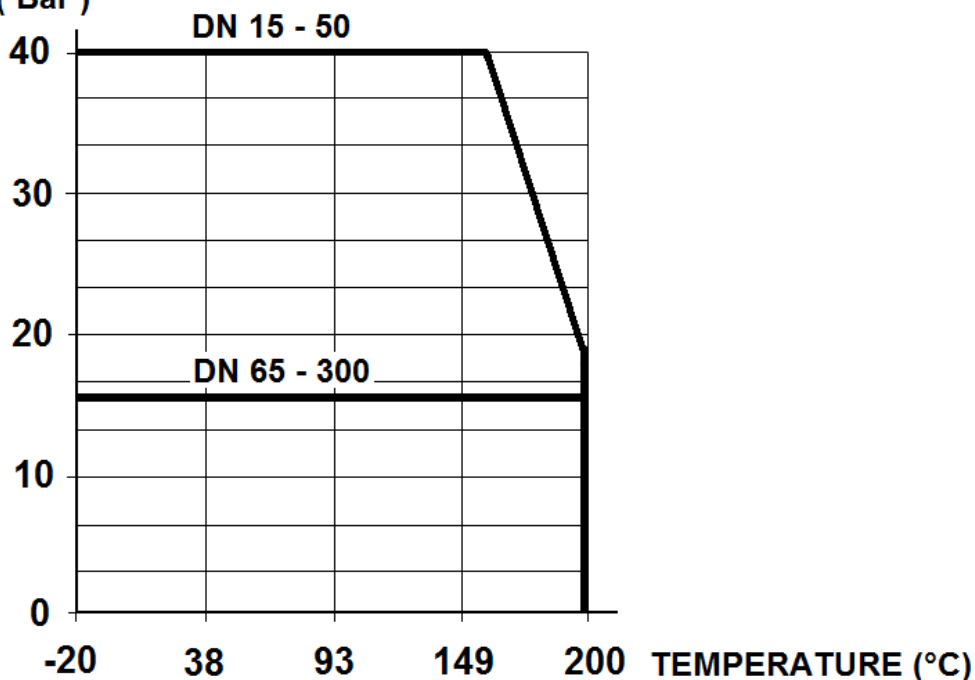

RANGE :

- Carbon steel body **Ref. 762** from DN 15 to DN 200 (with gearbox from DN250 to 300)
- Stainless steel body **Ref. 763** from DN 15 to DN 200 (with gearbox from DN250 to 300)
- Gearbox possible **Ref. 9830296-9830297** from DN 150 to DN 200

ENDS :

- R.F. Flanged ISO PN40 up to DN50, ISO PN16 over

2 PIECES BALL VALVES FLANGED ISO PN 16

MATERIALS DN 15 - 50 :

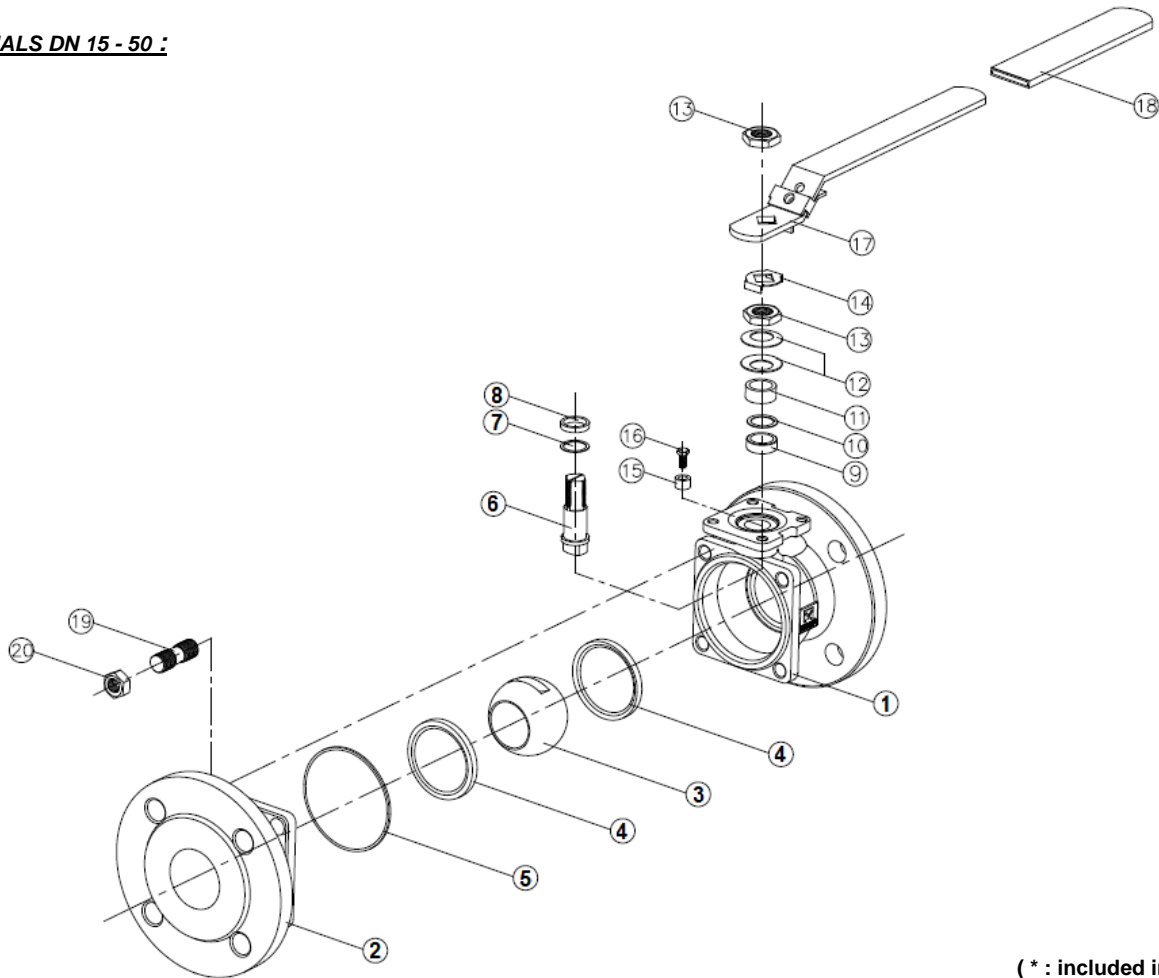

(* : included in gaskets kit)

Item	Designation	Materials 762	Materials 763
1	Body	ASTM A216 WCB	ASTM A351 CF8M
2	Ends	ASTM A216 WCB	ASTM A351 CF8M
3	Ball	ASTM A351 CF8M	
4*	Seat	PTFE filled with glass	
5*	Body seal	Graphite	
6	Stem	ASTM A276 316	
7*	Ring	PTFE filled with carbon	
8*	Ring	PTFE filled with carbon	
9*	Packing	Graphite	
10*	Packing	PTFE filled with carbon	
11	Packing gland	SS 304	
12	Elastic ring	SS 301	
13	Nut	SS 304	
14	Washer	SS 304	
15	Pin	SS 304	
16	Pin screw	SS 304	
17	Handle	SS 304	
18	Handle cover	PVC	
19	Stud	SS 304	
20	Nut	SS 304	

2 PIECES BALL VALVES FLANGED ISO PN 16

MATERIALS DN 65 - 100 :

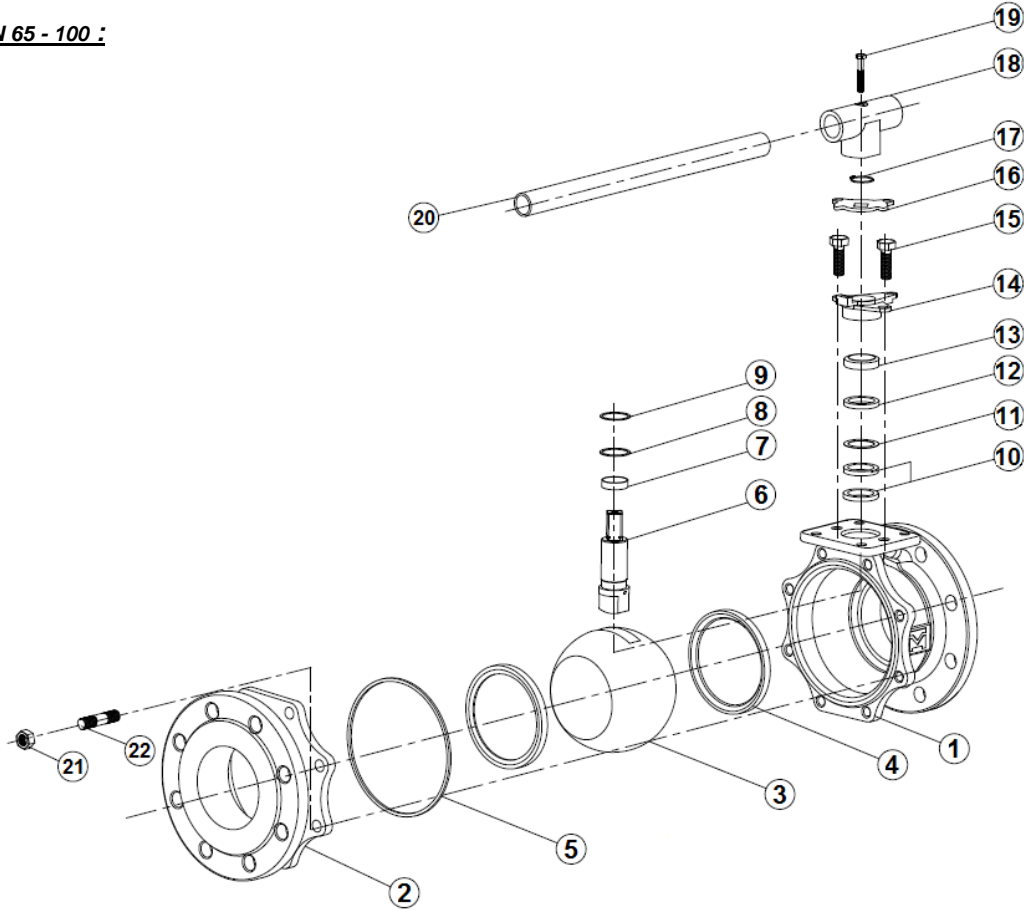

Item	Designation	Materials 762	Materials 763
1	Body	ASTM A216 WCB	ASTM A351 CF8M
2	Ends	ASTM A216 WCB	ASTM A351 CF8M
3	Ball	ASTM A351 CF8M	
4*	Seat	PTFE filled with glass	
5*	Body seal	Graphite	
6	Stem	ASTM A276 316	
7*	Ring	PTFE filled with carbon	
8*	Ring	PTFE filled with carbon	
9*	Ring	PTFE filled with carbon	
10*	Packing	Graphite	
11*	Packing	PTFE filled with carbon	
12	Ring	SS 304	
13	Ring	SS 304	
14	Packing gland	ASTM A351 CF8	
15	Packing gland screw	SS 304	
16	Pin	SS 304	
17	Circlips	SS 304	
18	Handle adaptor	ASTM A351 CF8	
19	Screw	SS 304	
20	Handle	SS 304	
21	Nut	SS 304	
22	Stud	SS 304	

(* : included in gaskets kit)

2 PIECES BALL VALVES FLANGED ISO PN 16

MATERIALS DN 125 - 200 :

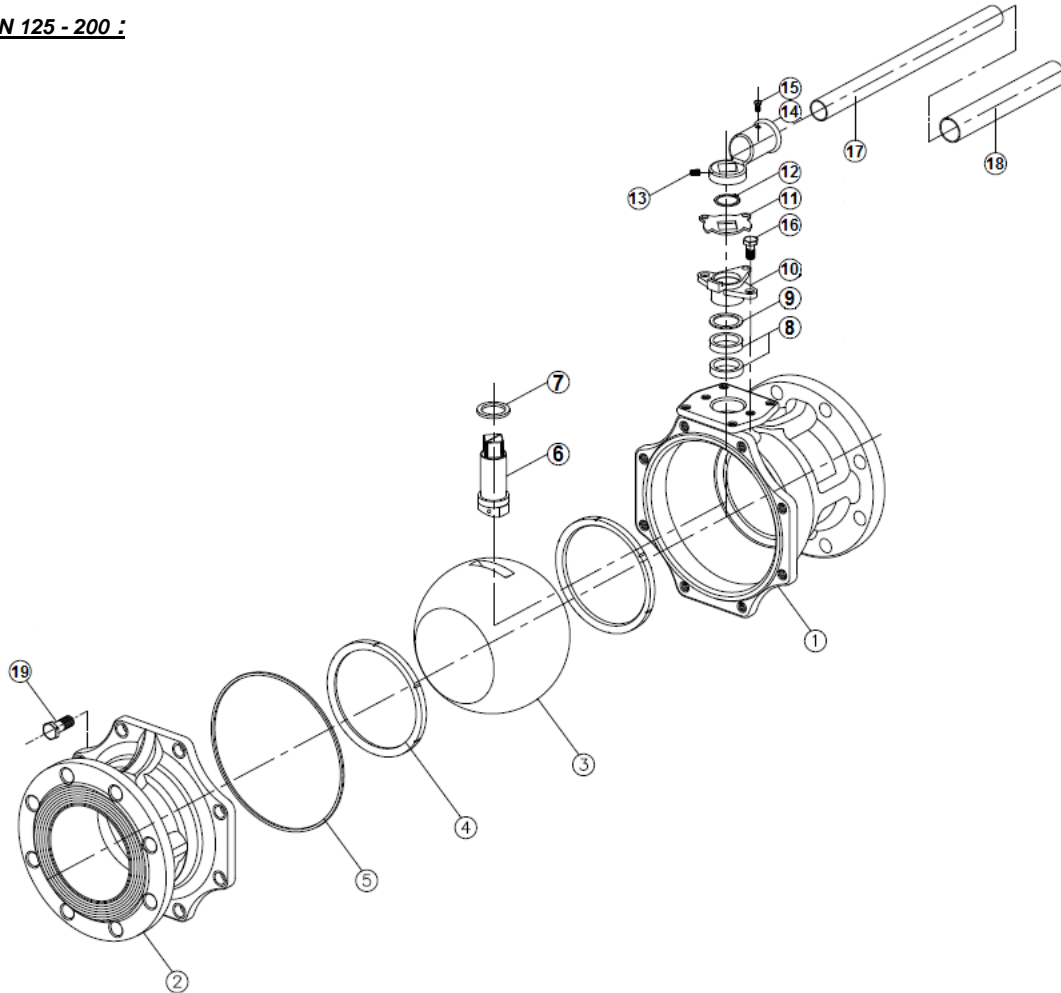

Item	Designation	Materials 762	Materials 763
1	Body	ASTM A216 WCB	ASTM A351 CF8M
2	Ends	ASTM A216 WCB	ASTM A351 CF8M
3	Ball	SS 316	
4*	Seat	PTFE filled with glass	
5*	Body seal	Graphite	
6	Stem	ASTM A276 316	
7*	Ring	PTFE filled with carbon	
8*	Packing	Graphite	
9*	Packing	PTFE filled with carbon	
10*	Packing gland	ASTM A351 CF8	
11	Pin	SS 304	
12	Circlips	SS 304	
13	Screw	SS 304	
14	Handle adaptor	SS 304	
15	Screw	SS 304	
16	Packing gland screw	SS 304	
17	Handle	SS 304	
18	Handle cover	PVC	
19	Body screw	SS 304	

(* : included in gaskets kit)

2 PIECES BALL VALVES FLANGED ISO PN 16

MATERIALS DN 250 :

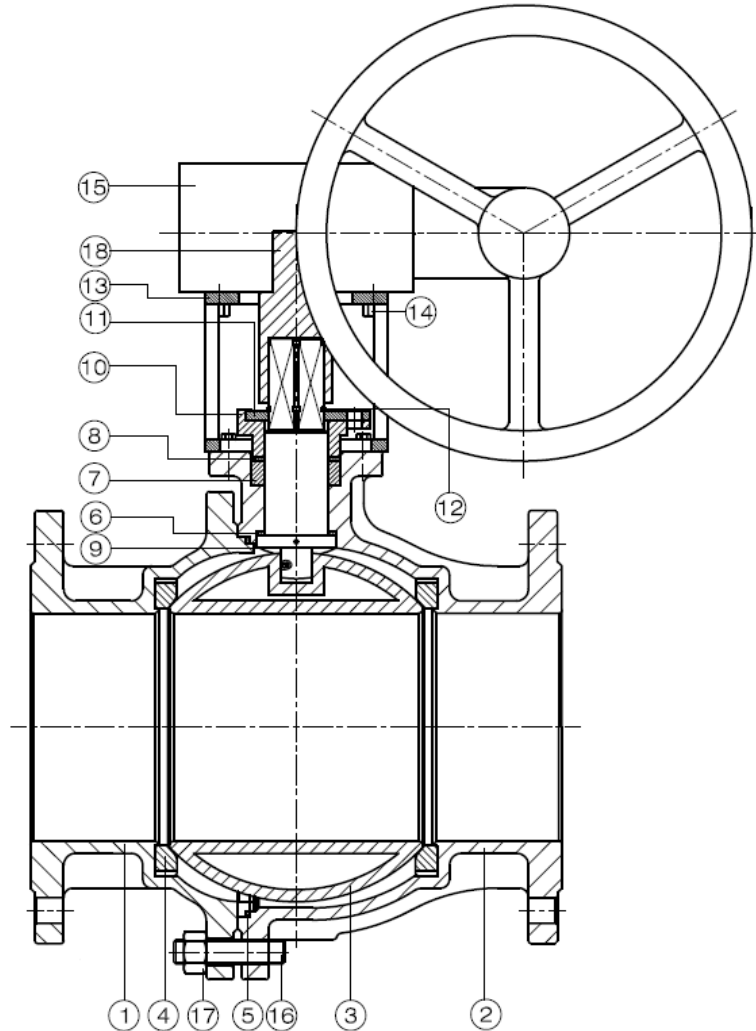

Item	Designation	Materials 762	Materials 763
1	Body	ASTM A216 WCB	ASTM A351 CF8M
2	Ends	ASTM A216 WCB	ASTM A351 CF8M
3	Ball	SS 316	
4*	Seat	PTFE filled with glass	
5*	Body gasket	Graphite	
6*	Ring	PTFE filled with carbon	
7*	Packing	Graphite	
8*	Packing	PTFE filled with carbon	
9	Stem	ASTM A276-316	
10	Gland	ASTM A351 CF8	
11	Gland bolt	SS 304	
12	Circlips	SS 304	
13	Yoke	SS 304	
14	Screw	SS 304	
15	Worm gear	ASTM A48-No.35	
16	Stud	SS 304	
17	Nut	SS 304	
18	Stem caput	SS 1045	

2 PIECES BALL VALVES FLANGED ISO PN 16

MATERIALS DN 300 :

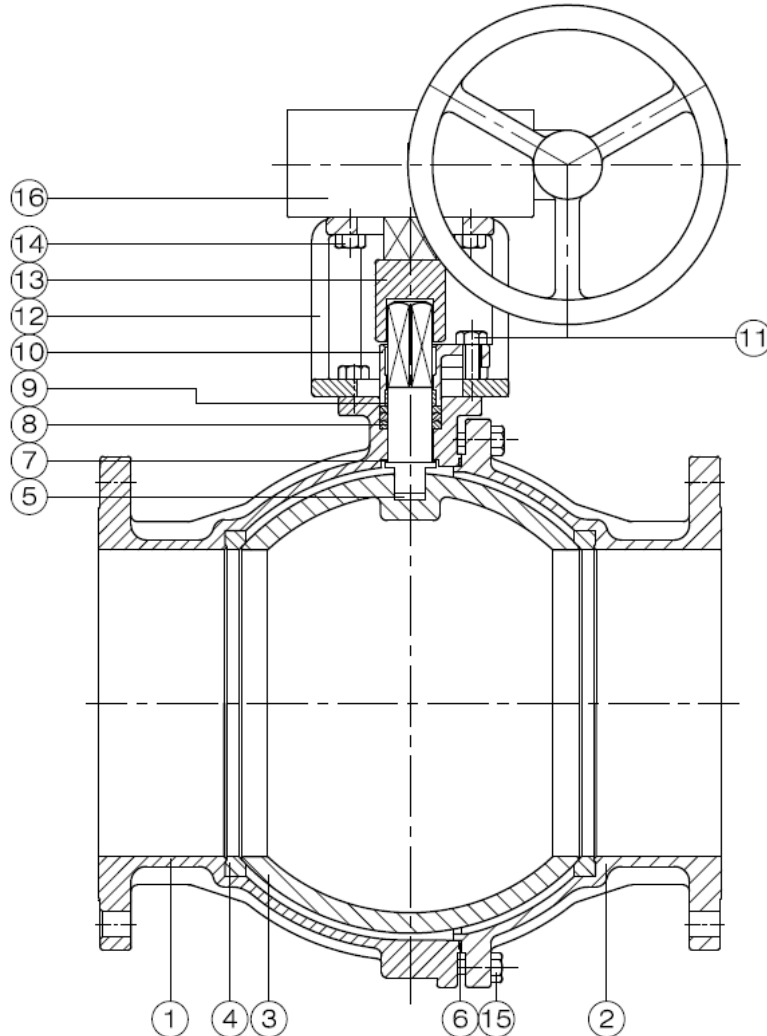

Item	Designation	Materials 762	Materials 763
1	Body	ASTM A216 WCB	ASTM A351 CF8M
2	Ends	ASTM A216 WCB	ASTM A351 CF8M
3	Ball	ASTM A351 CF8	ASTM A351 CF8M
4*	Seat	PTFE filled with glass	
5	Stem	SS 304	SS 316
6*	Body gasket	PTFE filled with glass	
7*	Ring	CTFE	
8*	Packing	PTFE filled with glass	
9*	Packing	PTFE	
10	Gland	ASTM A351 CF8	
11	Gland screw	Carbon steel	SS 304
12	Yoke	Cast iron FC20	
13	Stem caput	Carbon steel	
14	Yoke bolt	Carbon steel	SS 304
15	Body screw	Carbon steel	SS 304
16	Worm gear	Cast iron FC20	

2 PIECES BALL VALVES FLANGED ISO PN 16

SIZE DN 15 - 50 (in mm) :

DN 15 - 50

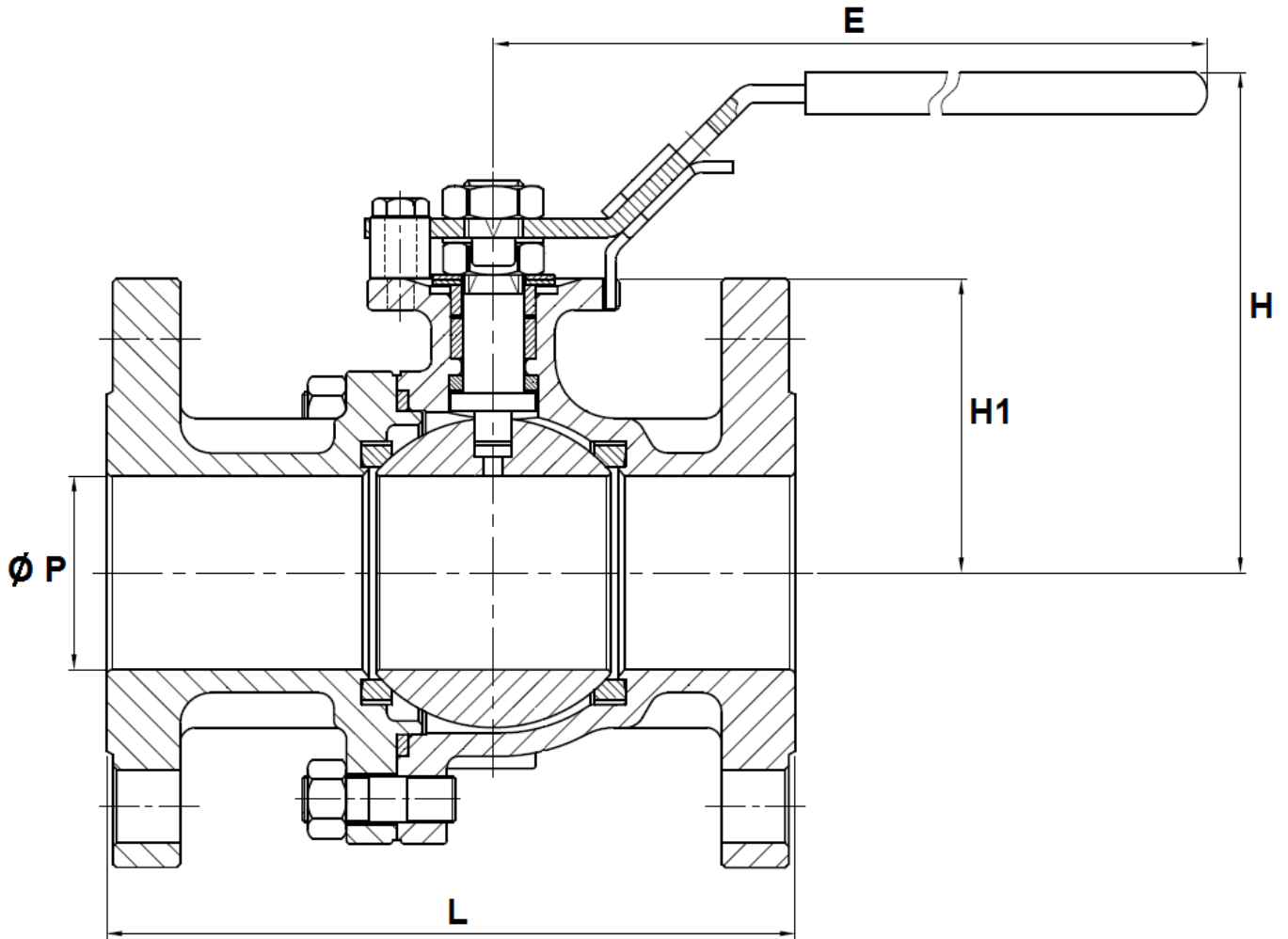

Ref.	DN	15	20	25	32	40	50
762 / 763	Ø P	15	20	24	30	38	50
	L	115	120	125	130	140	150
	E	158	158	196	196	245	261
	H	75.6	78.1	92	96	109.1	115.6
	H1	39	42.5	52	56	66	73
	Weight (Kg)	2.3	3	4	5.5	7	9.3

2 PIECES BALL VALVES FLANGED ISO PN 16

SIZE DN 65 - 100 (in mm) :

DN 65 - 100

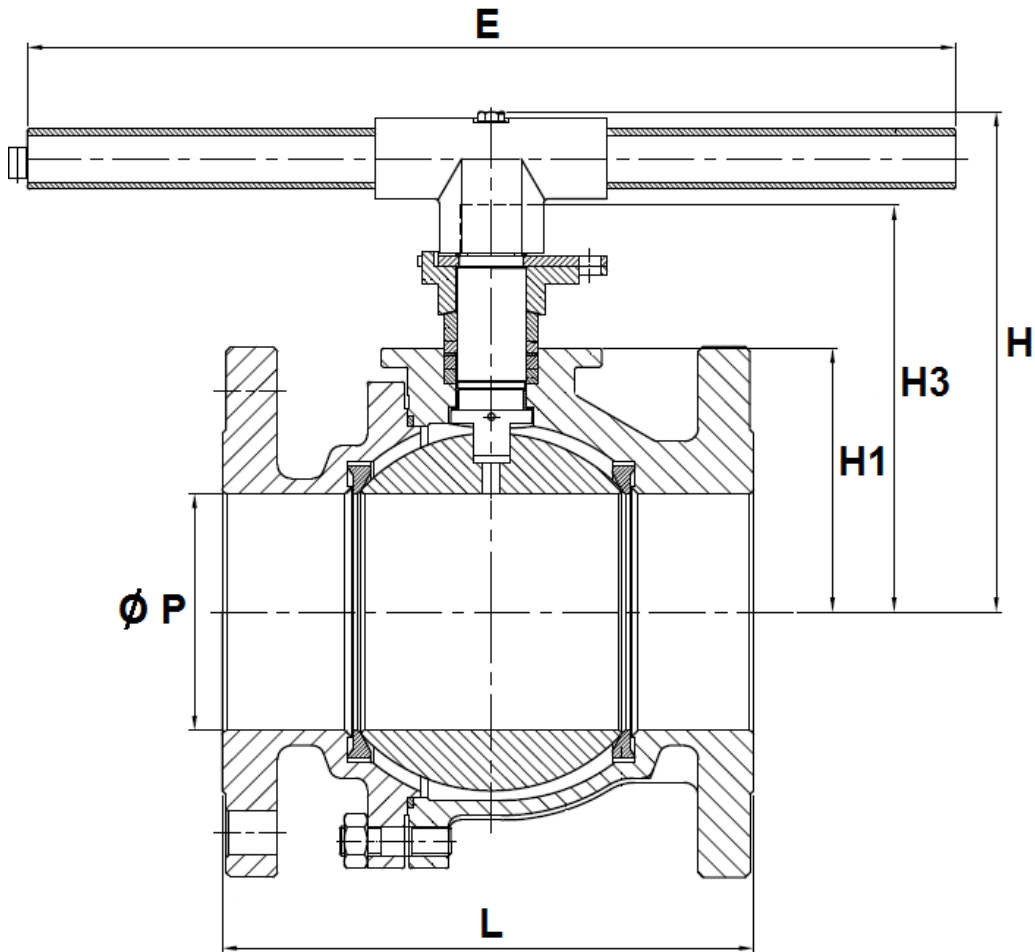

Ref.	DN	65	80	100
762 / 763	Ø P	64	76	98
	L	170	180	190
	E	400	400	400
	H	188	194	215
	H1	86.5	91.5	113.5
	H3	152	158	179
	Weight (Kg)	14.4	17.5	23.3

2 PIECES BALL VALVES FLANGED ISO PN 16

SIZE DN 125 - 200 (in mm) :

DN 125 - 200

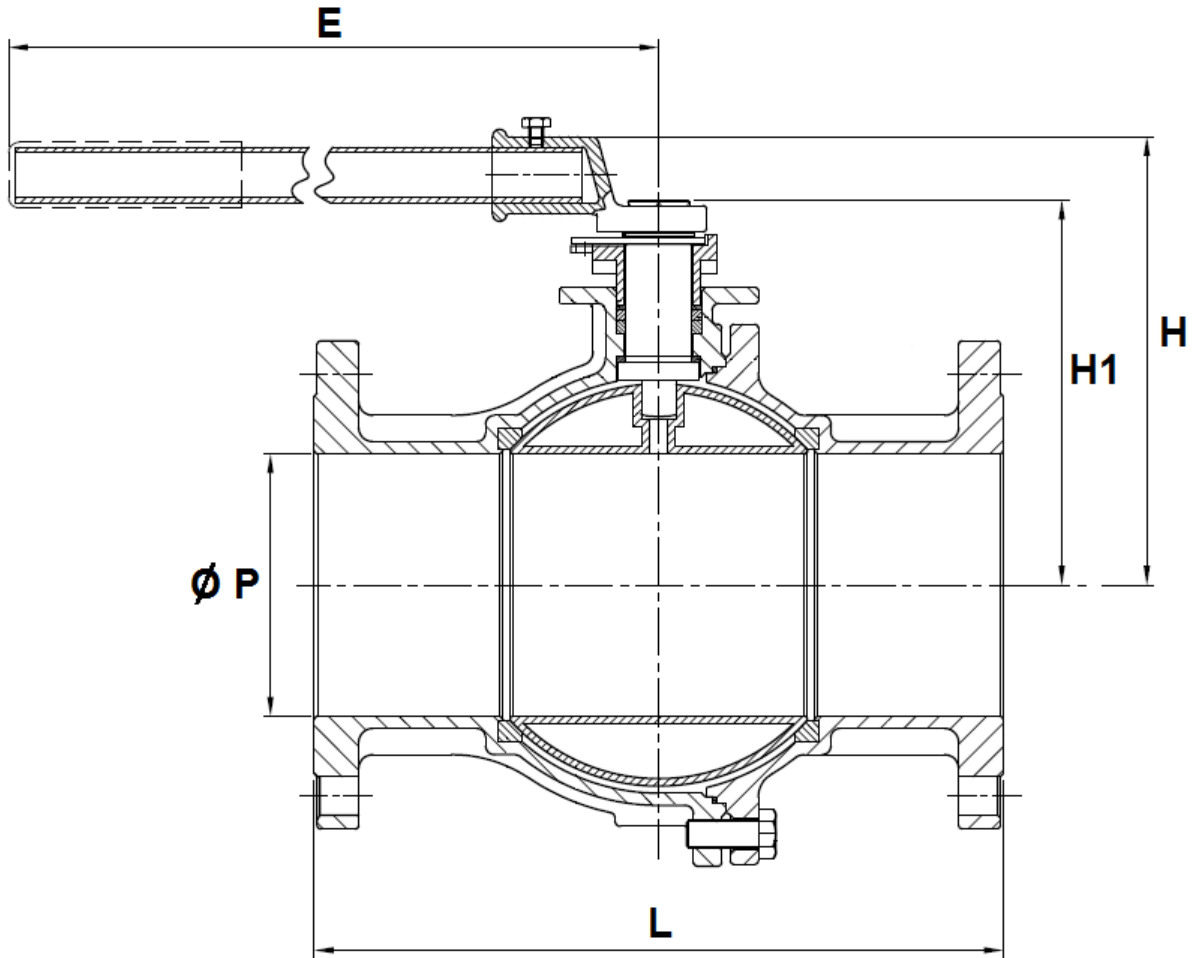

Ref.	DN	125	150	200
762 / 763	Ø P	125	150	200
	L	325	350	400
	E	743	743	925
	H	239.6	256.5	323.5
	H1	199	220	286.5
	Weight (in Kg)	36.7	52	78

2 PIECES BALL VALVES FLANGED ISO PN 16

SIZE DN 250 - 300 (in mm) :

DN 250

DN 300

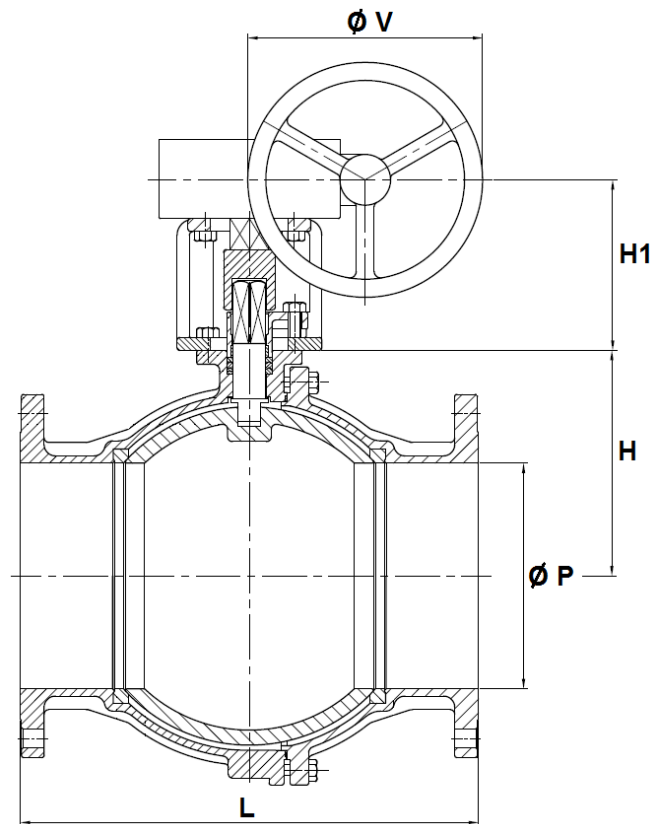
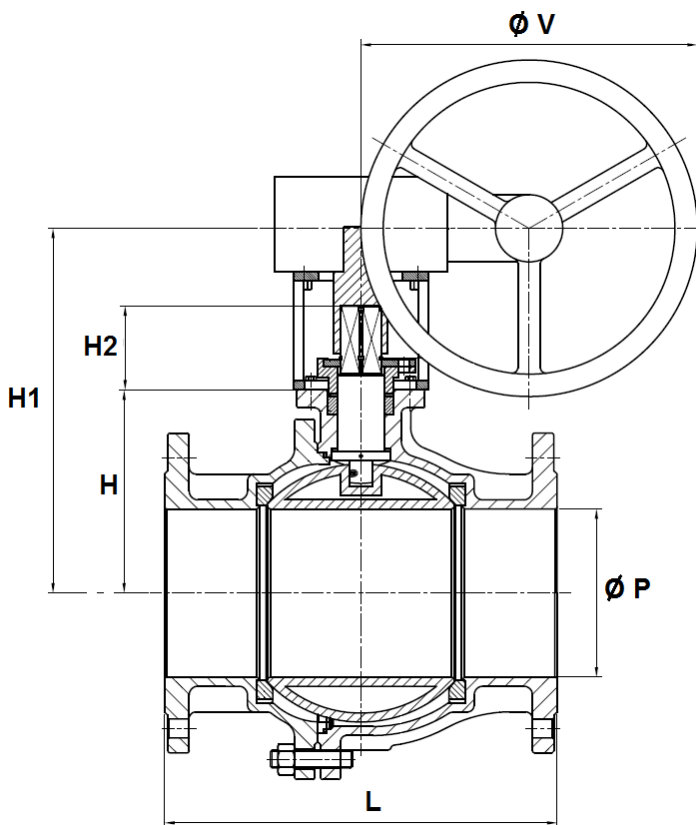

Ref.	DN	250	300
762 / 763	Ø P	250	300
	L	450	500
	Ø V	300	400
	H	260	293
	H1	393	193
	H2	85.5	-
	Weight (in Kg)	157	176.5

2 PIECES BALL VALVES FLANGED ISO PN 16

GEARBOX SIZE (in mm) :

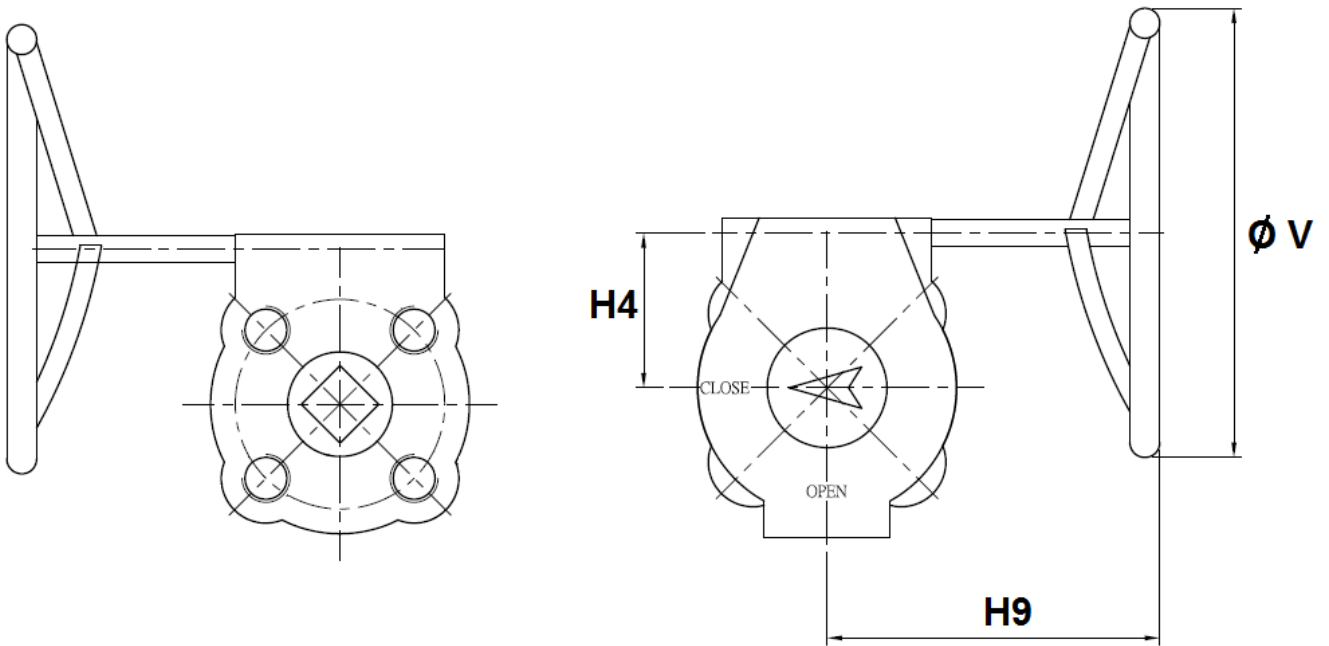

DN	150	200
H4	63	78
H9	238	226
Ø V	300	300
Weight (Kg)	12.5	15
Ref.	9830296	9830297

2 PIECES BALL VALVES FLANGED ISO PN 16

ISO MOUNTING PAD AND STEM SIZE (in mm) :

DN 15 – 50

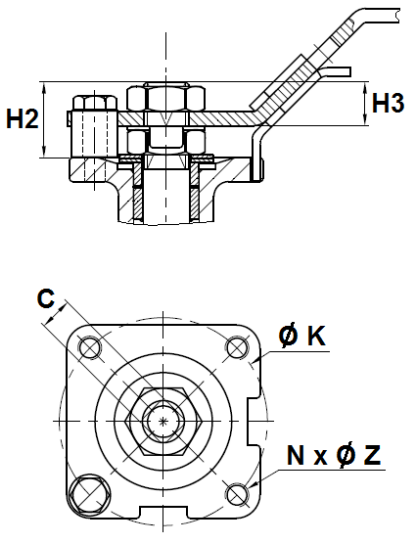

DN 65 – 100

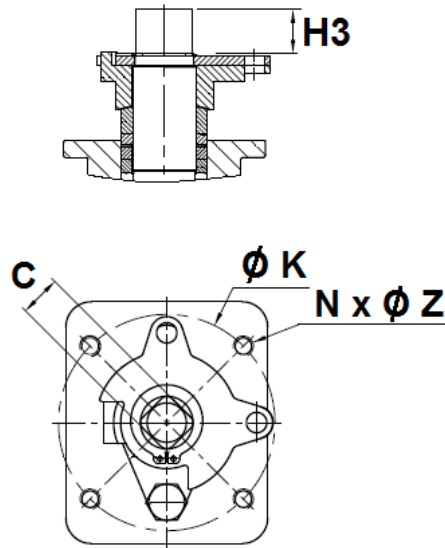

DN 125 - 200

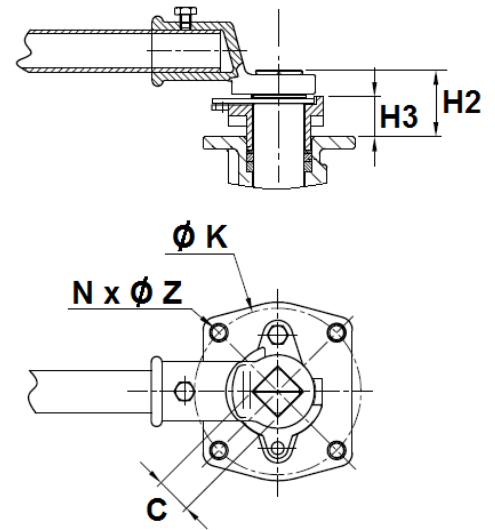

Ref.	DN	15	20	25	32	40	50	65	80	100	125	150	200
762 – 763	C	9	9	11	11	14	14	17	17	17	27	27	36
	Ø K	42	42	50	50	70	70	102	102	102	125	125	140
	ISO	F04	F04	F05	F05	F07	F07	F10	F10	F10	F12	F12	F14
	N x Ø Z	4xM5	4xM5	4xM6	4xM6	4xM8	4xM8	4xM10	4xM10	4xM10	4xM12	4xM12	4xM16
	H2	14.5	14	18	17	22	21.5	-	-	-	52	50	85.5
	H3	8.5	8.5	12	12	14	14	27	27	27	32	31	30

2 PIECES BALL VALVES FLANGED ISO PN 16

FLANGES SIZE (in mm) :

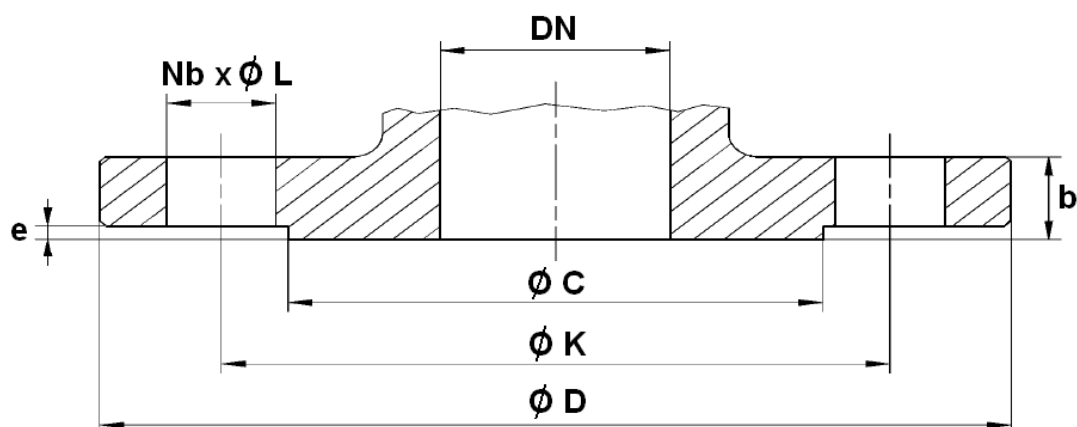

Ref.	DN	15	20	25	32	40	50	65
762 - 763	Ø C	45	58	68	78	88	102	122
	Ø D	95	105	115	140	150	165	185
	Ø K	65	75	85	100	110	125	145
	Nb x Ø L	4 x 14	4 x 14	4 x 14	4 x 18	4 x 18	4 x 18	4 x 18
	b	16	18	18	18	18	20	18
	e	2	2	2	2	3	3	3

Ref.	DN	80	100	125	150	200	250	300
762 - 763	Ø C	138	158	188	212	268	320	378
	Ø D	200	220	250	285	340	405	460
	Ø K	160	180	210	240	295	355	410
	Nb x Ø L	8 x 18	8 x 18	8 x 18	8 x 22	12 x 22	12 x 26	12 x 26
	b	20	20	22	22	24	26	28
	e	3	3	3	3	3	3	4

2 PIECES BALL VALVES FLANGED ISO PN 16

FLOW COEFFICIENT Kvs (M3 / h) :

DN	15	20	25	32	40	50	65	80	100	125	150	200	250	300
Kvs (m3/h)	31	58	86	139	229	415	698	983	1686	2824	3953	7225	7731	17994

TORQUE VALUES (in Nm without safety coefficient) :

DN	15	20	25	32	40	50	65	80	100	125	150	200	250	300
Torque (Nm)	8	10	12	20	30	40	60	90	130	160	250	500	750	1300

GEARBOX SPECIFICATIONS :

DN	150	200
Ref.	9830296	9830297
Ratio factor	30 :1	50 :1
Output torque (Nm)	700	1200

STANDARDS :

- Fabrication according to ISO 9001 : 2008
- DIRECTIVE 97/23/CE : CE N° 0035
Risk Category III Module H
- Construction according to EN 12516-1
- Tests according to API 598, table 6
- ISO PN16 R.F. flanges according to EN 1092-1 PN16
- ISO 5211 mounting pad
- Length according to EN 558 series 27 (DIN 3202 F4/F5)
- ATEX Group II Category 2 G/2D Zone 1 & 21 Zone 2 & 22 (optional marking)
- Fire safe according to API 607 5° edition up to DN100, 4° edition from DN125 to DN150

2 PIECES BALL VALVES FLANGED ISO PN 16

INSTALLATION INSTRUCTIONS

GENERAL GUIDELINES :

- Ensure that the valves to be used are appropriate for the conditions of the installation (type of fluid, pressure and temperature).
- Be sure to have enough valves to be able to isolate the sections of piping as well as the appropriate equipment for maintenance and repair.
- Ensure that the valves to be installed are of correct strength to be able to support the capacity of their usage.
- **Installation of all circuits should ensure that their function can be automatically tested on a regular basis (at least two times a year).**

INSTALLATION INSTRUCTIONS :

- **Before installing the valves, clean and remove any objects from the pipes** (in particular bits of sealing and metal) which could obstruct and block the valves.
- **Ensure that both connecting pipes either side of the valve (upstream and downstream) are aligned (if they're not, the valves may not work correctly).**
- **Make sure that the two sections of the pipe (upstream and downstream) match, the valve unit will not absorb any gaps. Any distortions in the pipes may affect the tightness of the connection, the working of the valve and can even cause a rupture.** To be sure, place the kit in position to ensure the assembling will work.
- **If sections of piping do not have their final support in place, they should be temporarily fixed. This is to avoid unnecessary strain on the valve.**
- Tighten the bolts in cross.
- It's recommended to operate the valve (open and close) 1 to 2 times per year