

**BRASS SWING CHECK VALVE PN10/16 ( 301-302-321-322 )**



**Size :** DN 3/8" to 4"  
**Ends :** Female BSP  
**Min Temperature :** + 0°C  
**Max Temperature :** + 90°C ( 60°C for 302 and 322 types )  
**Max Pressure :** 16 Bars ( 10 bars for 301-302 types )  
**Specifications :** Swing type  
Metal / metal thickness or EPDM ( NBR for DN  
2"1/2 à 4" )

**Materials :** Brass

## BRASS SWING CHECK VALVE PN10/16 ( 301-302-321-322 )

### SPECIFICATIONS :

- Vertical position with ascendant fluid or horizontal position ( respect the flow direction indicated by the arrow )
- Cylindric threaded female BSP ends
- Swing type
- Metal / metal thickness or EPDM ( NBR for DN2"1/2 à 4" )

### USE :

- For all common fluids
- Min Temperature Ts : + 0°C
- Max Temperature Ts :+ 90°C for 301 and 321 types
- Max Temperature Ts :+ 60°C for 302 and 322 types
- Max Pressure PN : 16 bars for 321 and 322 types, 10 bars for 301 and 302 types

### RANGE :

- Threaded BSP cylindric ends with metal/metal thickness PN10 from DN 3/8" to DN 4" **Ref. 301**
- Threaded BSP cylindric ends with EPDM seat PN10 from DN 3/8" to DN 2" **Ref. 302**
- Threaded BSP cylindric ends with NBR seat PN10 from DN 2"1/2 to DN 4" **Ref. 302**
- Threaded BSP cylindric ends with metal/metal thickness PN16 from DN 1/2" to DN 2" **Ref. 321**
- Threaded BSP cylindric ends with EPDM seat PN16 from DN 1/2" to DN 2" **Ref. 322**

### MATERIALS FOR METAL/METAL TYPES REF.301 and 321 :

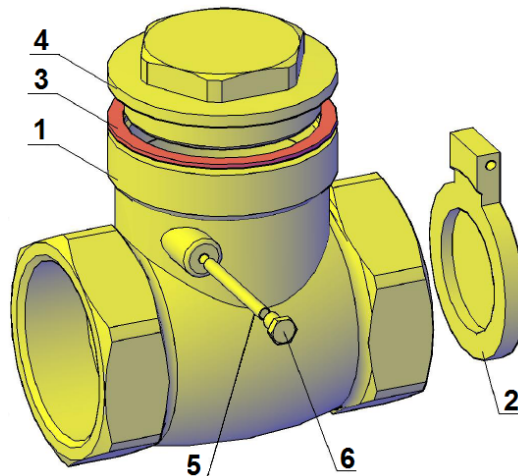

Item	Designation	Materials Ref. 301 DN 3/8" to 2" and 321	Materials Ref. 301 DN 2"1/2 to 4"
1	Body	Brass CW 617 N according to EN 12165	Brass CW 617 N according to EN 12165
2	Disc	Brass CW 617 N according to EN 12165	Brass CW 617 N according to EN 12165
3	Bonnet gasket	Fibers	NBR
4	Bonnet	Brass CW 617 N according to EN 12165	Brass CW 617 N according to EN 12165
5	Stem	Brass Hpb59-1	Brass Hpb59-1
6	Stem screw	Brass Hpb59-1	Brass Hpb59-1

**BRASS SWING CHECK VALVE PN10/16 ( 301-302-321-322 )**

MATERIALS FOR EPDM SEAT TYPES REF.302 and 322 :

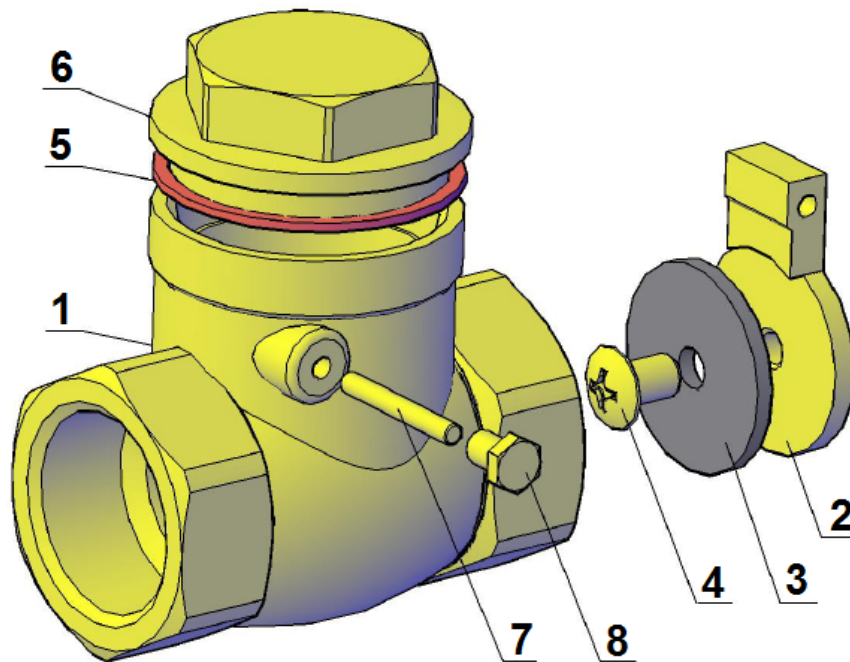

Item	Designation	Materials Ref. 302 DN 3/8" to 2" and 322	Materials Ref. 302 DN 2"1/2 to 4"
1	Body	Brass CW 617 N according to EN 12165	Brass CW 617 N according to EN 12165
2	Disc	Brass CW 617 N according to EN 12165	Brass CW 617 N according to EN 12165
3	Gasket	EPDM	NBR
4	Screw	Brass Hpb59-1	Brass CW614 N according to EN 12164
5	Bonnet gasket	Fibers	NBR
6	Bonnet	Brass CW 617 N according to EN 12165	Brass CW 617 N according to EN 12165
7	Stem	Brass Hpb59-1	Brass Hpb59-1
8	Stem screw	Brass Hpb59-1	Brass Hpb59-1

**BRASS SWING CHECK VALVE PN10/16 ( 301-302-321-322 )**

SIZE PN10 TYPE WITH METAL SEAT REF.301 ( in mm ):

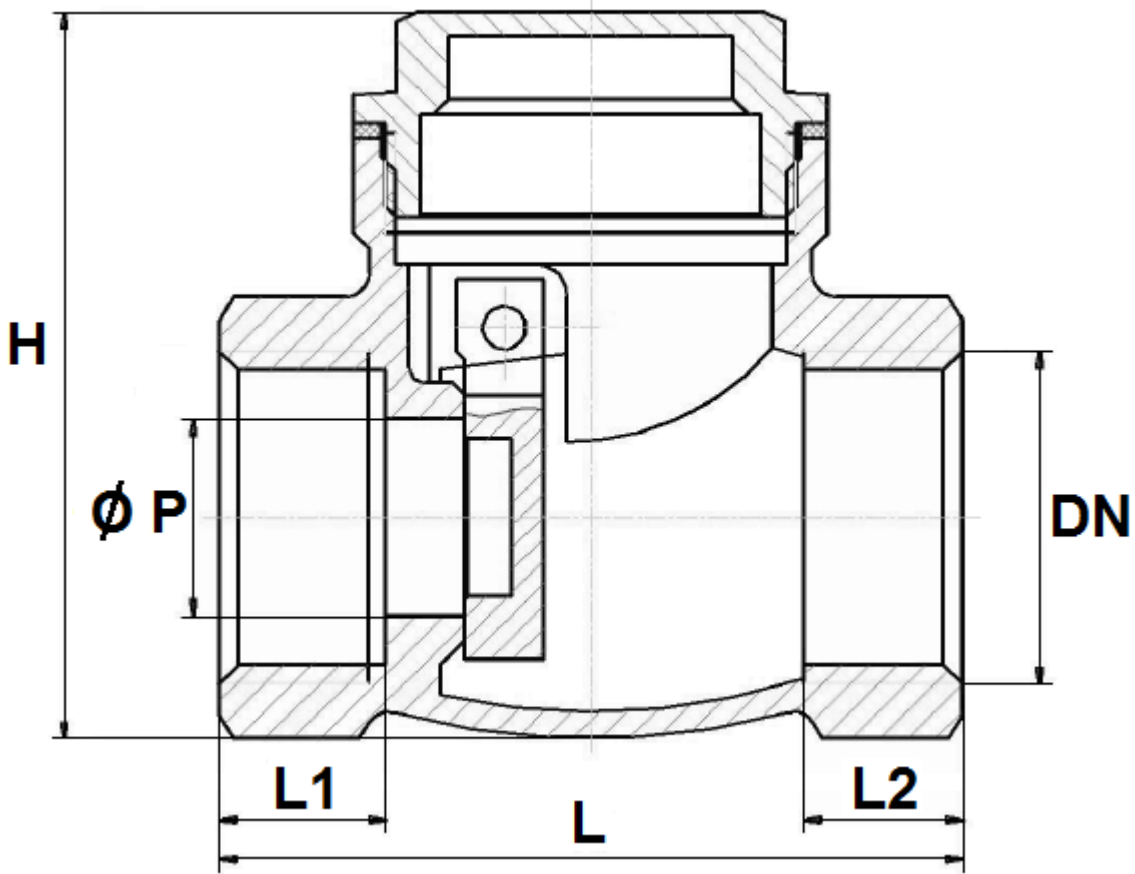

Ref.	DN	3/8"	1/2"	3/4"	1"	1"1/4	1"1/2	2"	2"1/2	3"	4"
301	Ø P	12	12.5	18.5	23.5	30	35	47	55	68	88
	L	47	47	53	63	70	88	97	116	135	164
	L1	10.5	10.5	12	13.5	17	18	19.5	16	16	20
	L2	10.5	10	12	12	14.5	17	19.5	16	16	20
	H	46	46	52	62	73	92	102	113	133	166
	Weight ( Kg )	0.120	0.140	0.200	0.340	0.430	0.760	1	1.570	1.879	3.764

**BRASS SWING CHECK VALVE PN10/16 ( 301-302-321-322 )**

SIZE PN10 TYPE WITH EPDM SEAT REF.302 ( in mm ):

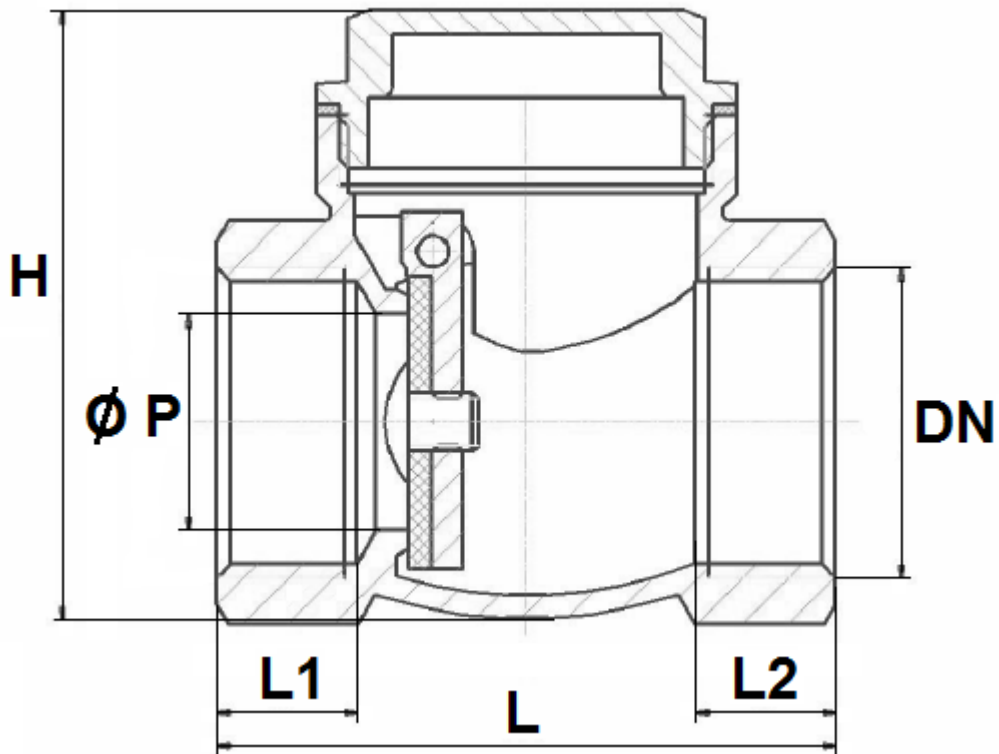

Ref.	DN	3/8"	1/2"	3/4"	1"	1"1/4	1"1/2	2"	2"1/2	3"	4"
302	Ø P	12	12.5	18.5	23.5	30	35	47	55	68	88
	L	47	47	53	63	70	88	97	116	135	164
	L1	10.5	10.5	12	13.5	17	18	19.5	16	16	20
	L2	10.5	10	12	12	14.5	17	19.5	16	16	20
	H	46	46	52	62	73	92	102	113	133	166
	Weight ( Kg )	0.120	0.140	0.200	0.340	0.430	0.760	1	1.579	2.253	3.837

**BRASS SWING CHECK VALVE PN10/16 ( 301-302-321-322 )**

**SIZE PN16 TYPE WITH METAL SEAT REF.321 ( in mm ):**

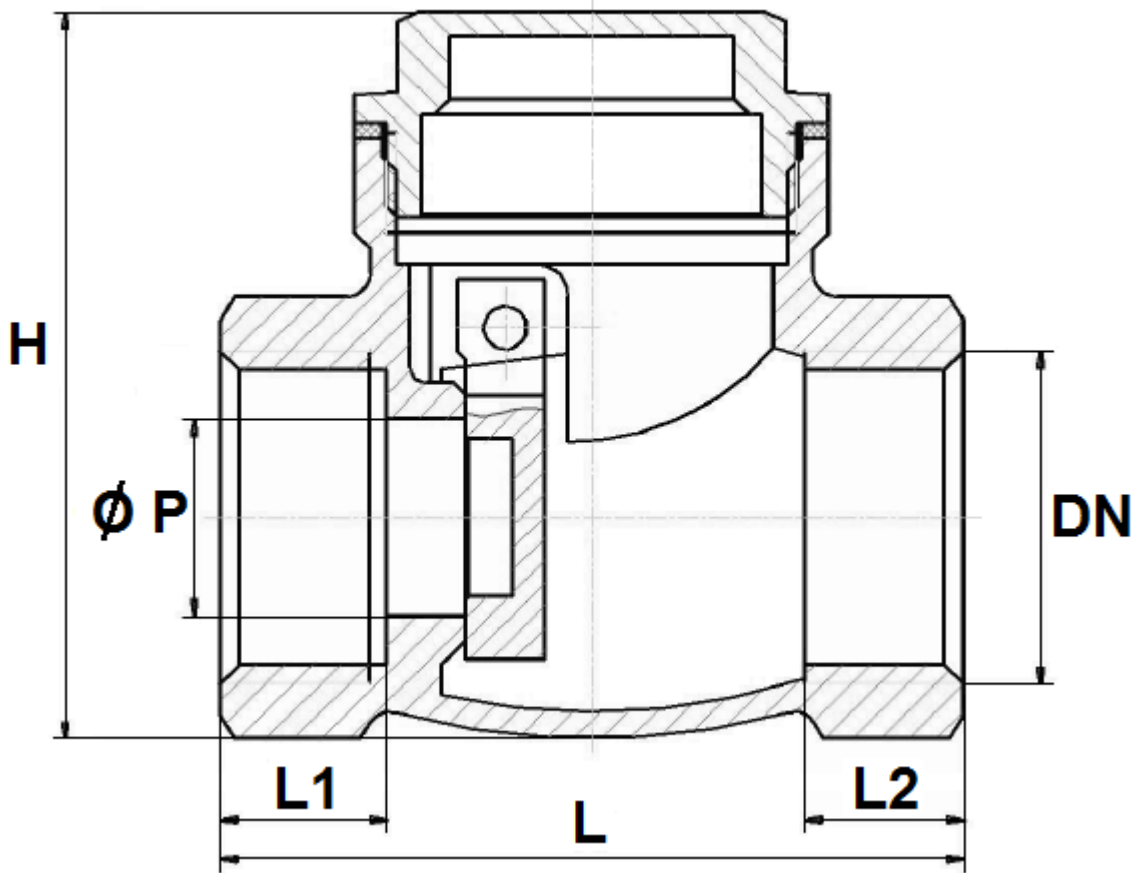

Ref.	DN	3/8"	1/2"	3/4"	1"	1"1/4	1"1/2	2"
321	Ø P	12	12.5	18.5	23.5	30	35	47
	L	49	49	58	70	80	88	102
	L1	11.5	10.5	12.5	15.5	17	18	21
	L2	11.5	10	12.5	14	17	17	21
	H	52	51	61	69	87	96.5	111
	Weight ( Kg )	0.160	0.185	0.285	0.440	0.580	0.870	1.200

**BRASS SWING CHECK VALVE PN10/16 ( 301-302-321-322 )**

SIZE PN16 TYPE WITH EPDM SEAT REF.322 ( in mm ):

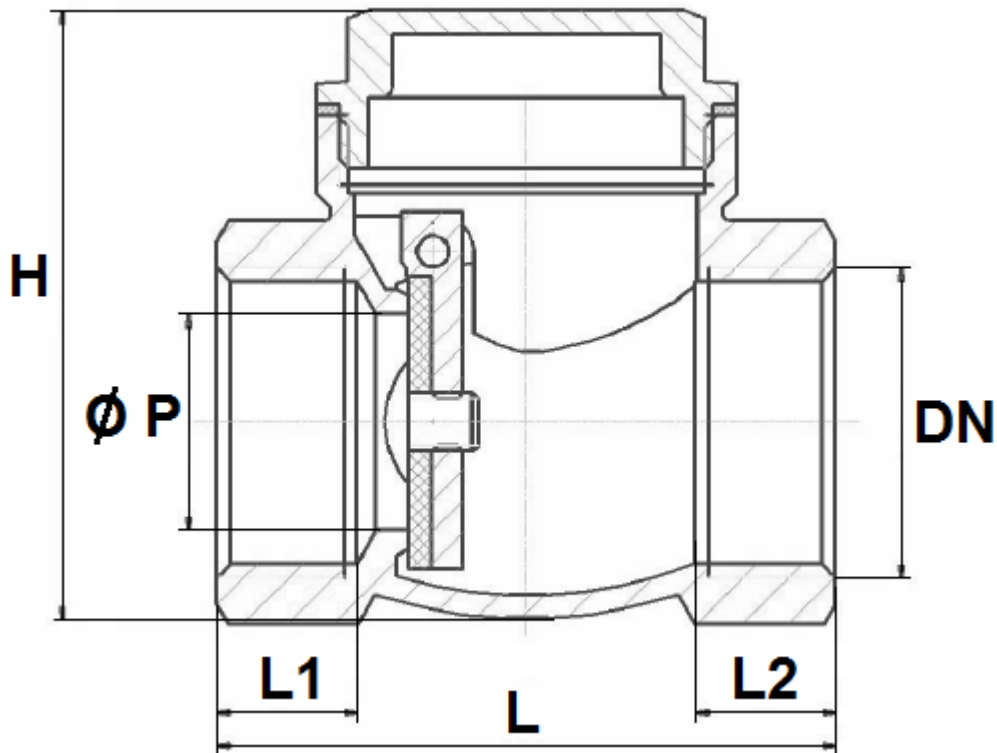

Ref.	DN	3/8"	1/2"	3/4"	1"	1"1/4	1"1/2	2"
322	Ø P	12	12.5	18.5	23.5	30	35	47
	L	49	49	58	70	80	88	102
	L1	11.5	10.5	12.5	15.5	17	18	21
	L2	11.5	10	12.5	14	17	17	21
	H	51	52	61	69	87	96.5	111
	Weight ( Kg )	0.160	0.185	0.290	0.440	0.580	0.870	1.200

**BRASS SWING CHECK VALVE PN10/16 ( 301-302-321-322 )**

**STANDARDS :**

- Fabrication according to ISO 9001 :2008 ( except Refs 301 and 302 from DN 2"1/2 to 4" )
- DIRECTIVE 97/23/CE : Products excluded from directive (article 1, § 3.2)
- Threaded female BSP cylindric ends

**INSTALLATION POSITIONS :**

**Vertical position ( ascendant fluid )**

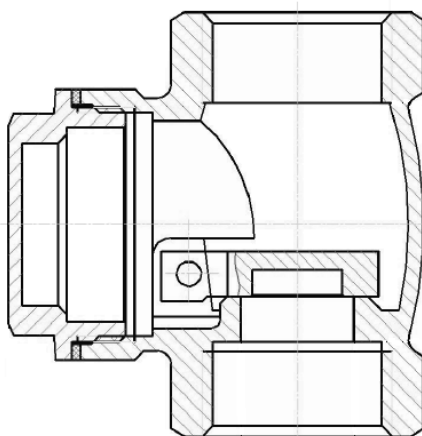

**Horizontal position**

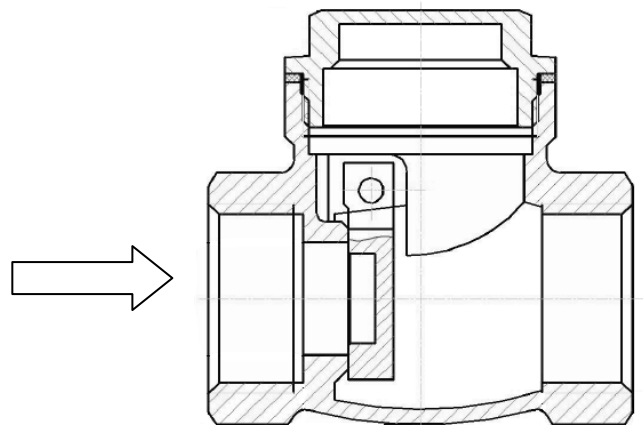

**ADVICE :** Our opinion and our advice are not guaranteed and SFERACO shall not be liable for the consequences of damages. The customer must check the right choice of the products with the real service conditions.



**BRASS SWING CHECK VALVE PN10/16 ( 301-302-321-322 )****INSTALLATION INSTRUCTIONS****GENERAL GUIDELINES :**

- Ensure that the check valves to be used are appropriate for the conditions of the installation (type of fluid, pressure and temperature).
- Be sure to have enough valves to be able to isolate the sections of piping as well as the appropriate equipment for maintenance and repair.
- Ensure that the valves to be installed are of correct strength to be able to support the capacity of their usage.

**INSTALLATION INSTRUCTIONS :**

- **Before installing the check valves, clean and remove any objects from the pipes** (in particular bits of sealing and metal) which could obstruct and block the valves.
- **Ensure that both connecting pipes either side of the check valve (upstream and downstream) are aligned (if they're not, the valves may not work correctly).**
- **Make sure that the two sections of the pipe (upstream and downstream) match, the check valve unit will not absorb any gaps. Any distortions in the pipes may affect the tightness of the connection, the working of the check valve and can even cause a rupture.** To be sure, place the kit in position to ensure the assembling will work.
- **If sections of piping do not have their final support in place, they should be temporarily fixed. This is to avoid unnecessary strain on the check valve.**
- If there is a direction changing or if there's another material, it's better to take away the check valve so that it is outside the turbulence area ( **between 3 and 5 times the ND before and after** ).
- After a pump please refer to norm NF CR 13932 to install the check valve.